

Model M-5 Sphere Detector Switch

- Pressure balanced, piston actuated proximity switch requiring no dynamic seals.
- Precision machined and factory sealed with only one moving part, requiring no adjustment in the field. The proximity switch is set inline in a fixed position. This results in less maintenance, therefore avoiding expensive downtime and unscheduled recalibrations. The results are years of trustworthy maintenance-free service.
- Dimensional and Switch Contact Certification available to Shell Test Stand Benchmark
- Directly interchangeable with all earlier model Metric switches.
- Adapters available to fit most any mounting configuration.
- Available in SPDT or DPDT contacts.
- Available to meet NACE or Low-Temp services.
- Designs available for above or below ground installation.



***MAG-TEK™ PROVES IT
With Thousands in Service!***

There is a reason why year after year people have placed their trust in the MAG-TEK switch for reliable accurate repeatability during meter prover runs.

IT WORKS!



Class I, Division 1,
Groups C and D
Hazardous Locations.

NRTL/C

Patent No.
US 6,789,407 B1



(918) 445-1141

(800) 331-3790

Fax: (918) 445-4617

www.weamco.com

Model M-5 Sphere Detector Switch Specifications

Switch Element

CONTACT:	Environmentally Sealed
RATING:	2 Amps @ 240 V.A.C. 50 Milliamps @ 24 V.D.C.
RESPONSE TIME:	0.008 Seconds
TEMPERATURE:	-40 F to +221 F
PRESSURE RATING:	2220 PSIG
REPEATABILITY:	0.002" (Under identical operating conditions)

Switch Enclosure

WELD-ON BASE PLATE:	Carbon Steel
SPRING:	302 Stainless
PISTON:	416 Stainless
BODY:	303 Stainless
O-RING:	Viton
CONDUIT OPENING:	1/2" N.P.T.
SWITCH TERMINATION:	Labeled Leads

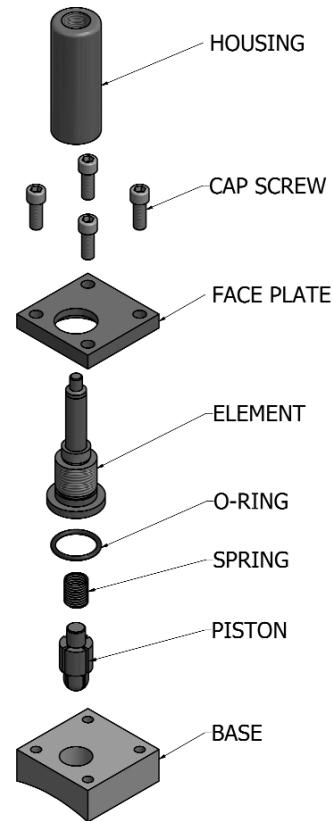

ADAPTERS TO FIT MOST MOUNTING CONFIGURATIONS



PECO/SMITH
MALONEY



MODERN



MAINTENANCE
MECHANICAL



KIDD



METER
ENGINEERS

Also Available - Halmor, Older Smith & Custom Adapters

HOW TO ORDER:

1. Quantity
2. Pipe Size
3. Wall Thickness
4. Contact SPDT or DPDT

For Adaptors:

Please contact our office for the proper dimensions to verify your application.



(918) 445-1141

(800) 331-3790

Fax: (918) 445-4617

www.weamco.com