

# Corrosion Coupon Holder

**For inserting and retrieving a Corrosion Measurement Coupon in a pipeline under operating pressures to 5,000 PSI.**

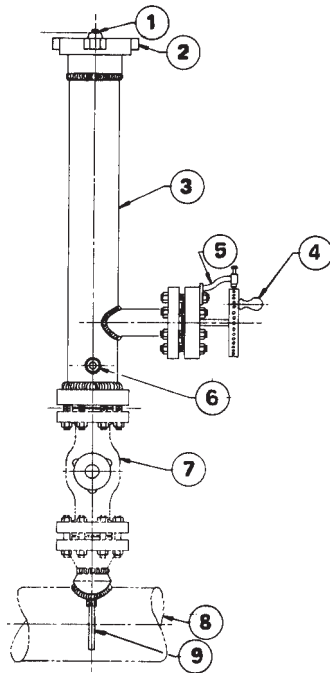

## TYPE CH-100 (Flange Mount)

2" 150/300/400/600/900/1500/2500 RF or RJ  
2" API Type 6 B 3,000 PSI or 5,000 PSI

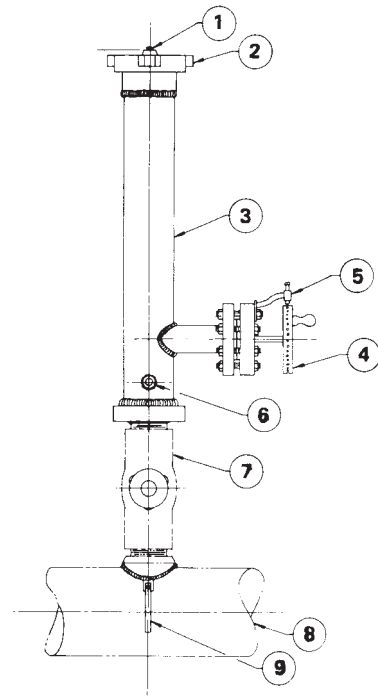
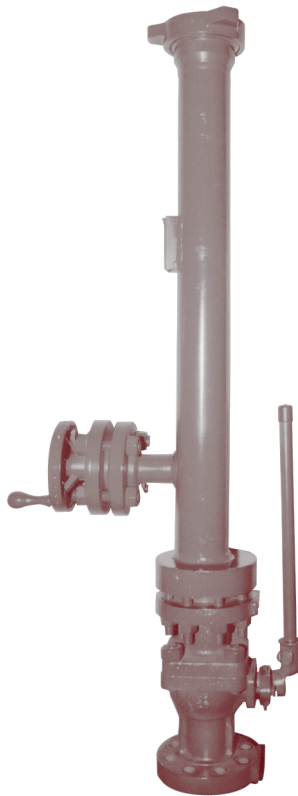

## CH-200 (Threaded Mount)

2" Male NPT

### KEY TO ABOVE DIAGRAMS

ITEM	DESCRIPTION
1	1/4" NPT Vent with Plug
2	ANSI Quick Opening Closure
3	Seamless Carbon Steel Body
4	Handwheel
5	Handwheel Lock
6	1/2" NPT Drain with Plug
7	2" Full Opening Valve
8	Pipeline
9	Coupon in Down Position

**SAFE RAPID EASY** Requiring one man only a few minutes, with NO SPECIAL TOOLS, to change a corrosion measurement coupon in a pipeline while under continuous operating pressure. The coupon holder accepts a 1/2" wide by 1/8" thick coupon, and features a Teflon seat to eliminate electrolytic corrosion. The gear rack with coupon is lowered into the line through use of a pinion gear on a stainless steel shaft driven by an external handwheel. The shaft is sealed against internal pressure by two Viton O-rings. Thrust bearings are used on both ends of the pinion shaft for ease of operation. The unit can be installed in either the vertical or horizontal position. Standard design and construction in accordance with ASME/ANSI B31.4. The unit can also be manufactured in accordance with AMSE/ANSI B31.3 and ASME/ANSI B31.8. Each unit is hydrostatically tested to 1 1/2 times design pressure. Sizes available to fit most pipe diameters.

Patent # 4,120,313

### INFORMATION REQUIRED FOR ORDERING

1. Type (CH-100 or CH-200)
2. Pipeline size and Wall thickness
3. ANSI Rating or design pressure and temperature



(918) 445-1141

(800) 331-3790

Fax: (918) 445-4617

www.weamco.com

Bulletin CH303



## **CORROSION COUPON HOLDER**

### **CH-100 and CH-200**

### **INSTALLATION, OPERATION & MAINTENANCE INSTRUCTIONS**

## **I. INSTALLATION**

The installation of either the CH-100 or CH-200 model requires a 2" pipeline tap and 2" full opening (full port) ball valve, screwed or flanged end, depending upon the model. The coupon holder is mounted directly to the valve with the handle arm parallel to the pipeline for the coupon to be parallel with the flow.

## **II. OPERATION**

### **A. Loading Holder**

With ball valve in off position, remove the quick opening closure cap, loosen handwheel lock, and turn handwheel counter clockwise until gear rack becomes accessible from the inner guide. Pull rack straight out of the top. The coupon can then be installed on the teflon seat provided on the end gear rack. See sketch. Note: The holder accepts a 1/2" wide x 1/8" thick coupon.

### **B. Locating Coupon Within Pipeline**

Insert rack slowly into guide and slide it down until it engages with the pinion and can be lowered into the body by turning the handwheel clockwise. Replace closure and secure. Open 2" valve and lower coupon into line by turning handwheel clockwise until the coupon touches the far ID of the pipe. Mark handwheel location with respect to the handwheel lock. Each indentation on the OD of the hand wheel represents 1/8" of rack (or coupon) travel. Turn handwheel counter-clockwise to raise coupon to desired position in the pipeline by noting the number of indentations passed. Secure with locking screw.

### **C. Retrieving Coupon**

Loosen locking screw and turn handwheel counter-clockwise until it will go no further. Close 2" valve. Bleed internal pressure from holder, then proceed to remove coupon.

## **III. MAINTENANCE**

The only maintenance required is lubrication of the moving parts. The rack and pinion assembly should be greased every 12 to 18 months, depending upon amount of usage and service (lubricating or non-lubricating pipeline product).

The pinion assembly is removed by loosening set screw in handwheel and removing. Next remove the blind flange, which will pull the shaft and shaft support with seals. The pinion shaft can then be pulled from the bearing housing. A light film of commercially available lithium-based grease should be applied to pinion shaft, pinion gear and rack. Pinion sealing O-Rings (P/N 100-18) can be replaced while the pinion shaft is removed. Replace only if a leak has occurred around the pinion shaft. When reinstalling pinion shaft, take care not to damage or tear the O-Rings.

The quick opening closure should have the threads and O-Ring cleaned with fresh grease applied after each removal.

## **IV. RECOMMENDED SPARE PARTS**

- (2) P/N 100-16 O-Rings for Quick Opening Closure, Buna-N
- (4) P/N 100-18 Pinion Sealing O-Ring, Viton
- (2) P/N 100-10 Teflon Insulator
- (2) P/N 100-13 Seat, Teflon

Consult factory for additional parts required and ordering.

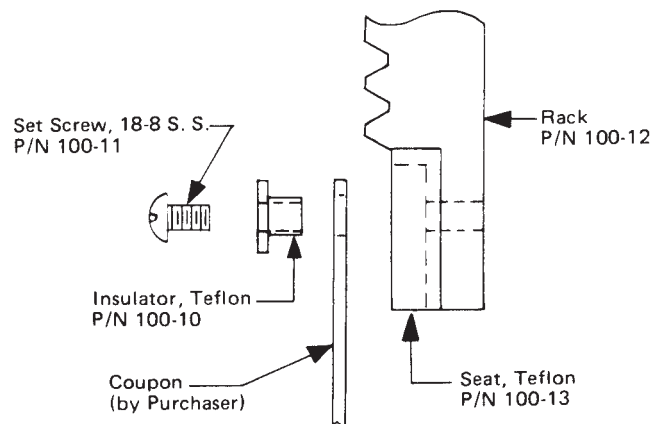

(918) 445-1141  
(800) 331-3790  
Fax: (918) 445-4617  
[www.weamco.com](http://www.weamco.com)